



TSW200

INDUSTRIAL POE+ ETHERNET SWITCH



Energy & utilities



Enterprise



Industrial & automation



Retail



Smart city

SFP

2 x SFP ports for long-range Fiber-optic communication

POE+

8 x PoE+ ports with 802.af, 802.3at standard support

POWER BUDGET

Total power budget at PSE up to 240 W

ETHERNET

8 x Gigabit Ethernet with speeds up to 1000 Mbps

Ethernet

ETH	8 x ETH ports, 10/100/1000 Mbps, supports auto MDI/MDIX crossover
Fibre	2 x SFP ports
IEEE 802.3 series standards	802.3i, 802.3u, 802.3ab, 802.3x, 802.3az, 802.3z

INDUSTRIAL PROTOCOLS

Profinet	Profinet Class A conformance (available with optional order code)
----------	---

POE OUT

PoE+ ports	Port 1 - 8
PoE standards	IEEE 802.3af (PoE, Type 1) and IEEE 802.3at (PoE+, Type 2), Alternative A (From batch 42) IEEE 802.3af (PoE, Type 1) and IEEE 802.3at (PoE+, Type 2), Alternative B (From batch 1-41)
PoE Max Power per Port (at PSE)	30 W
Total PoE Power Budget (at PSE)	240 W

Performance Specifications

Bandwidth (Non-blocking)	20 Gbps
Packer buffer	128 KB
MAC address table size	2K entries
Jumbo frame support	9216 bytes

Power

Connector	2-pin industrial DC power socket
Input voltage range	7 – 57 VDC
PoE-Out input voltage range	44 – 57 VDC
Power consumption	Idle: 1.81 W / Max: 5.5 W / PoE Max: 245.5 W

Surge at AC mains power port**: 1kV Line to line; 2kV line to ground, 1.2/50us, IEC 61000-4-5
Surge at signal port (Ethernet): 1kV Line to Ground, 1.2/50us, IEC 61000-4-5

**Tested with Teltonika's PSU. Test does not apply to direct DC power.

Physical Interfaces

Ethernet	8 x RJ45 ports, 10/100/1000 Mbps
Fibre	2 x SFP ports
Status LEDs	1 x Power LED, 16 x ETH status LEDs 2 x SFP status LEDs
Power	1 x 2-pin industrial DC power socket
Other	1 x Grounding screw

Physical Specification

Casing material	Full aluminium housing
Dimensions (W x H x D)	132 x 44.2 x 95.1 mm
Weight	517 g
Mounting options	Integrated DIN rail bracket; wall mount and flat surface (additional kit needed)

Operating Environment

Operating temperature	-40 °C to 75 °C
Operating humidity	5% to 95% non-condensing
Ingress Protection Rating	IP30

Regulatory & Type Approvals

Regulatory	CE, UKCA, CITC, ANRT, FCC, IC, CB
------------	-----------------------------------

EMC Emissions & Immunity

Standards	EN 55032:2015 + A1:2020 EN 55035:2017 + A11:2020 EN IEC 61000-3-2:2019 + A1:2021 EN 61000-3-3:2013 + A1:2019
ESD	EN 61000-4-2:2009
Radiated Immunity	EN IEC 61000-4-3:2020
EFT	EN 61000-4-4:2012
Surge Immunity (AC Mains Power Port)	EN 61000-4-5:2014 + A1:2017
CS	EN 61000-4-6:2014
DIP	EN IEC 61000-4-11:2020

Safety

Standards	IEC 62368-1:2018 EN IEC 62368-1:2020+A11:2020
-----------	--

Hardware

FRONT VIEW

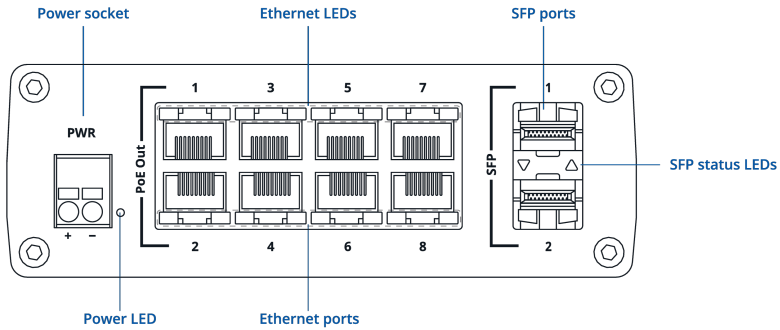

BACK VIEW

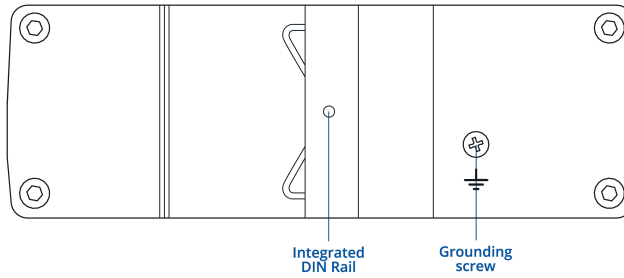

RJ45 LED MEANING

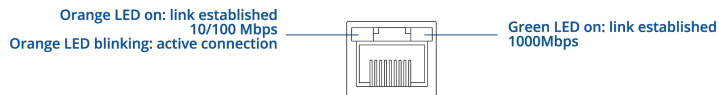

POWER SOCKET PINOUT

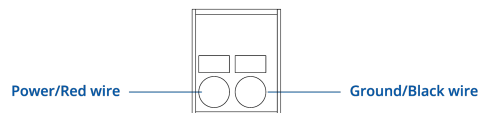

SFP LED MEANING

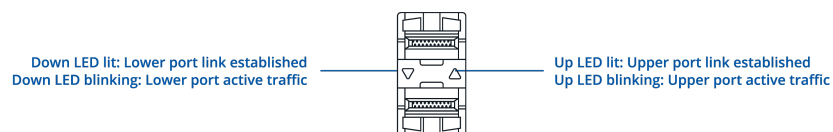

Ordering

Standard package*



TSW200



QUICK START GUIDE

*Standard package contents may differ based on standard order codes.

For more information on all available packaging options – please [contact us](#) directly.

Classification codes

HS Code: 851762

HTS: 8517.62.00

For more information on all available packaging options – please [contact us](#) directly.

Available versions

Hardware version	Supported frequencies	Standard order code / Package Contains
TSW200 *****0	N/A	TSW2000000B0 / Standard package without PSU TSW200000040 / Standard package with EU PSU(62W) without connector TSW200000060 / Standard package with EU PSU(250W) without connector TSW200000070 / Standard package with US PSU without connector TSW200000090 / Standard package with UK PSU without connector
TSW200 *****1 Profinet Class A conformance	N/A	TSW200000051 / Standard package without PSU

TSW200 spatial measurements

Available versions

Device housing (W x H x D)*	132 x 44.2 x 95.1 mm
Box:	135 x 47 x 107 mm

*Housing measurements are presented without antenna connectors and screws; for measurements of other device elements look to the sections below

TOP VIEW

The figure below depicts the measurements of device and its components as seen from the top:

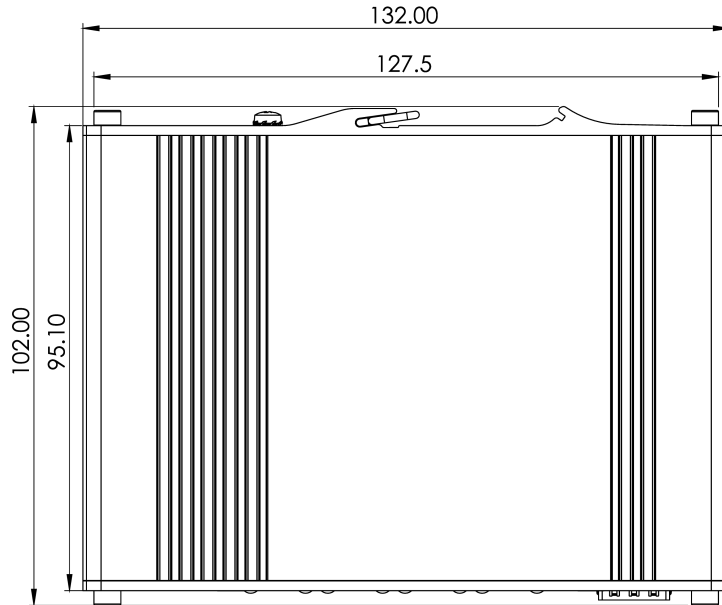

RIGHT VIEW

The figure below depicts the measurements of device and its components as seen from the right side:

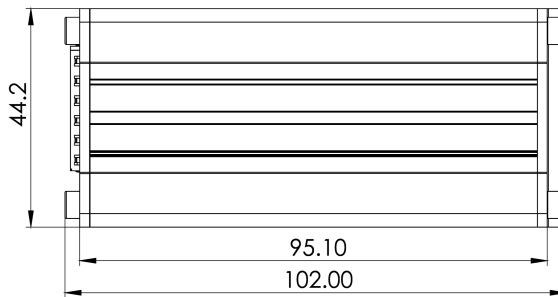

FRONT VIEW

The figure below depicts the measurements of device and its components as seen from the front panel side:

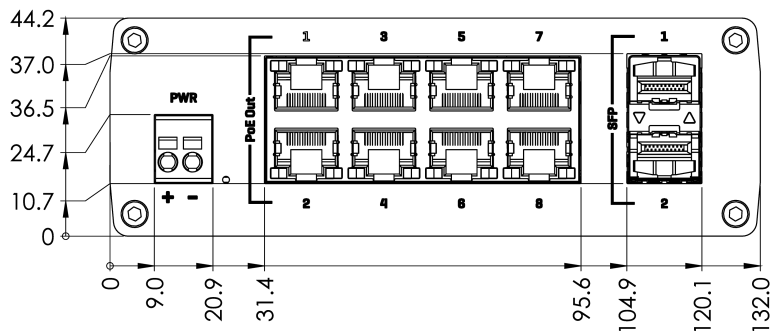

REAR VIEW

The figure below depicts the measurements of device and its components as seen from the back panel side:

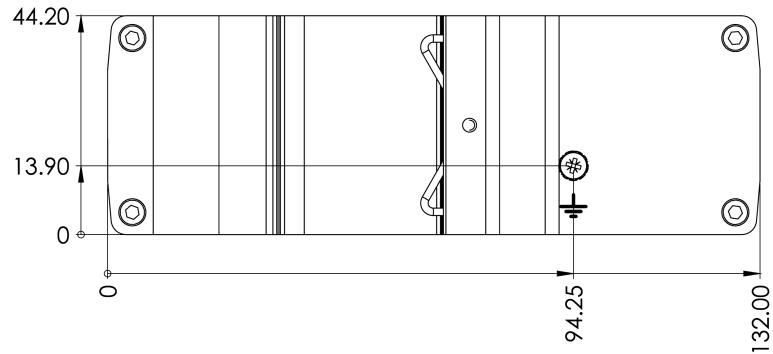

MOUNTING SPACE REQUIREMENTS

The figure below depicts an approximation of the device's dimensions when cables and antennas are attached:

